

Frontier® JUNIOR™



Esco Frontier Junior™ Laboratory Fume Hood,
Model EFB-4A_.

Laboratory Fume Hoods

Introduction

The Esco Frontier Junior Fume Hood combines innovative features such as a revolutionary baffle design and an 8° sloped front, maximizing operator safety and offering improved ergonomics at an affordable price.

Superstructure

- Combined single wall / double wall construction allows service fixture remote controls and electrical outlets to be mounted out of the work zone within easy reach.
- Internal liner is constructed of electrogalvanized steel with a corrosion and abrasion resistant oven-baked epoxy-polyester hybrid Isocide™ antimicrobial powder-coated finish.
- Corrosion-resistant epoxy powder coated electrogalvanized steel airfoil safely ventilates fumes generated towards the front of the hood for superior operator protection.
- Revolutionary baffle design optimizes airflow & improves containment within the work zone.
- Standard vertical rising fail safe counterbalanced sash constructed of tempered safety glass maximizes operator safety. The safety mechanism causes the sash to tilt and lock if a cable snaps.
- 1 remote-control gas fixture and 1 remote-control water fixture are provided with every hood.
- 2 electrical outlets are provided with every hood (total rating 5A).

Aesthetics and Ergonomics Design

- Perfect Pitch Profile - The gentle pitch of the hood enhances visibility and enables users to work further into the hood without strain.
- The angled front is also an aesthetic feature that positions your laboratory for the 21st century.
- Complementary color scheme of neutral white with blue accents blends the hood with any casework, metal or wood.
- Hood lighting is pre-wired. Lighting is electronically ballasted, energy efficient, instant start. Typical light intensity on work surface is >780 lux (>72 foot candles) in zero ambient conditions.
- Color temperature is tuned to provide a gentle, bright (but not harsh) and comfortable work environment for the user.

1

ESCO

WORLD CLASS. WORLDWIDE.

Serviceability

- Supplied with no work top for easy adaptability to any work surface.
- Esco Frontier Junior Fume Hoods ship unassembled to save freight costs, and for convenience during transport especially when the fume hood needs to be installed in a laboratory with a narrow door or hallway.
- Simple assembly procedure means quicker utilization upon delivery.

Safety Certified and Tested

All Esco fume hoods are manufactured for the most demanding laboratory applications.

- Independently tested and certified by Invent, UK to meet the requirement of the ANSI/ASHRAE 110-1995 Standard.
- Hoods are ASHRAE tested on the production line on a sampling basis (industry exclusive).
- Sash is clearly labeled with all operating instructions and illustrations.



Service fixture outlet is mounted on the cabinet.

2

General Specifications, Frontier Junior Fume Hoods				
Model	EFB-4A	EFB-5A	EFB-6A	
Nominal size	1.2 meters (4')	1.5 meters (5')	1.8 meters (6')	
External Dimensions (W x D x H)	1200 x 795 x 1461 mm 47.2" x 31.3" x 57.5"	1500 x 795 x 1461 mm 59.0" x 31.3" x 57.5"	1800 x 795 x 1461 mm 70.9" x 31.3" x 57.5"	
Internal Work Area, Dimensions (W x D x H)	1050 x 600 x 1228 mm 41.3" x 23.6" x 48.3"	1350 x 600 x 1228 mm 53.1" x 23.6" x 48.3"	1650 x 600 x 1228 mm 70.0" x 23.6" x 48.3"	
Maximum Sash Opening	560 mm (22")			
Exhaust Volume / Static Pressure Required Face Velocity of 0.5m/s (100fpm) at Full Open Sash	1058 cmh @ 61 Pa 623 cfm @ 0.25" WG	1361 cmh @ 75 Pa 801 cfm @ 0.30" WG	1663 cmh @ 88 Pa 979 cfm @ 0.35" WG	
Exhaust Outlet External Diameter	260 mm (10.2")			
Number of Exhaust Outlets	1	1	1	
Light Intensity at Work Surface	> 780 Lux (> 72 foot candles)			
Construction	Main Body: Oven-baked epoxy-polyester powder-coated EG steel			
Power Consumption	25W (Fluorescent light only)			
Electrical*	220-240V, AC, 50Hz, 1Ø	EFB-4A1	EFB-5A1	EFB-6A1
	Cabinet Full Load Amps (FLA)	10 A	10 A	10 A
	Cabinet BTU**	205	341	341
	110-120V, AC, 60Hz, 1Ø	EFB-4A2	EFB-5A2	EFB-6A2
	Cabinet Full Load Amps (FLA)	10 A	10 A	10 A
	Cabinet BTU**	205	341	341
	220-240V, AC, 60Hz, 1Ø	EFB-4A3	EFB-5A3	EFB-6A3
	Cabinet Full Load Amps (FLA)	10 A	10 A	10 A
	Cabinet BTU**	205	341	341
	110-120V, AC, 50Hz, 1Ø	EFB-4A4	EFB-5A4	EFB-6A4
	Cabinet Full Load Amps (FLA)	10 A	10 A	10 A
	Cabinet BTU**	205	341	341
100-110V, AC, 50/60Hz, 1Ø	EFB-4A7	EFB-5A7	EFB-6A7	
Cabinet Full Load Amps (FLA)	10 A	10 A	10 A	
Cabinet BTU**	205	341	341	
Controller	Rocker Switches			
Net Weight	143 kg (315 lbs)	167 kg (368 lbs)	196 kg (432 lbs)	
Shipping Weight	207 kg (456 lbs)	238 kg (525 lbs)	272 kg (599 lbs)	
Shipping Dimensions, Maximum (W x D x H)	1680 x 1300 x 700 mm 66.1" x 51.2" x 27.6"	1680 x 1300 x 700 mm 66.1" x 51.2" x 27.6"	1950 x 1300 x 700 mm 76.8" x 51.2" x 27.6"	

* The maximum rating of all the electrical outlets combined is 5 Amp. Please contact Esco if you need electrical outlets with higher capacity.
Note: EFB only shipped unassembled, minimum order quantity is 2 units per size, units can be double / triple stacked on a pallet.

** Cabinet BTU = Cabinet nominal power x 3.41214

Frontier JUNIOR™

Fume Hoods • Laboratory Fume Hoods

Model EFB Frontier Junior Fume Hood Technical Specifications

Top View (for EFB-4, EFB-5, EFB-6)

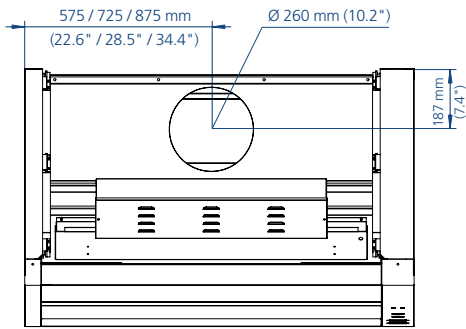

- | | |
|----------------------------------|-----------------------------------|
| 1. Exhaust collar | 6. Electrical outlet |
| 2. Electrical panel | 7. Remote control service fixture |
| 3. Fluorescent lamp | 8. Sash window |
| 4. Panel-mounted service fixture | 9. Rocker switches |
| 5. Airfoil | 10. Front panel |

Front View

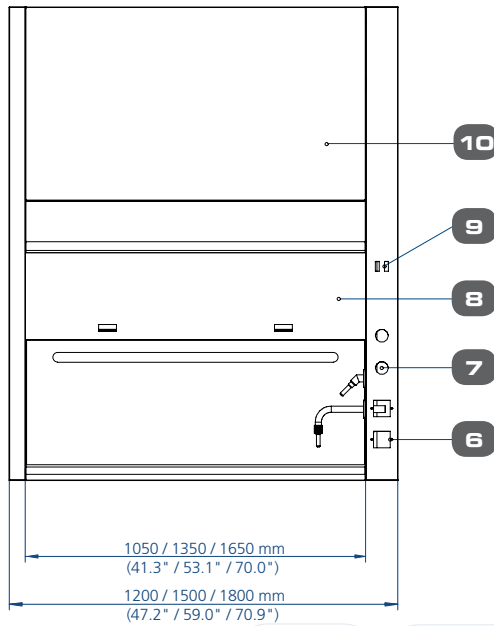

Side View

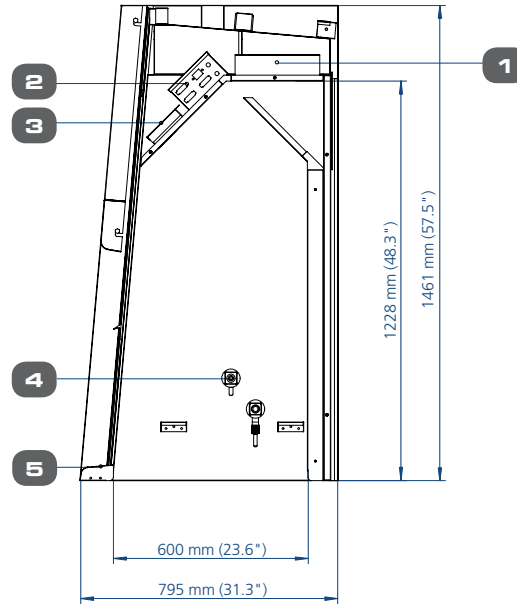

Remote control service fixture is mounted on the cabinet.



Rocker switches

Fume Hood Installation Requirements

- Proper location (refer to Esco recommendations)
- Exhaust system capable of delivering airflow and pressure drop requirements
 - Exhaust ductwork and connection accessories
 - Exhaust blower (or building exhaust system)
 - Contactor (if applicable)
 - Means of adjusting exhaust flow (damper or frequency inverter)
- Sufficient laboratory supply air
- Base cabinet or other means of support
- Plumbing and electrical hook-up
- Unless otherwise specified, items and services specified above are not provided by Esco

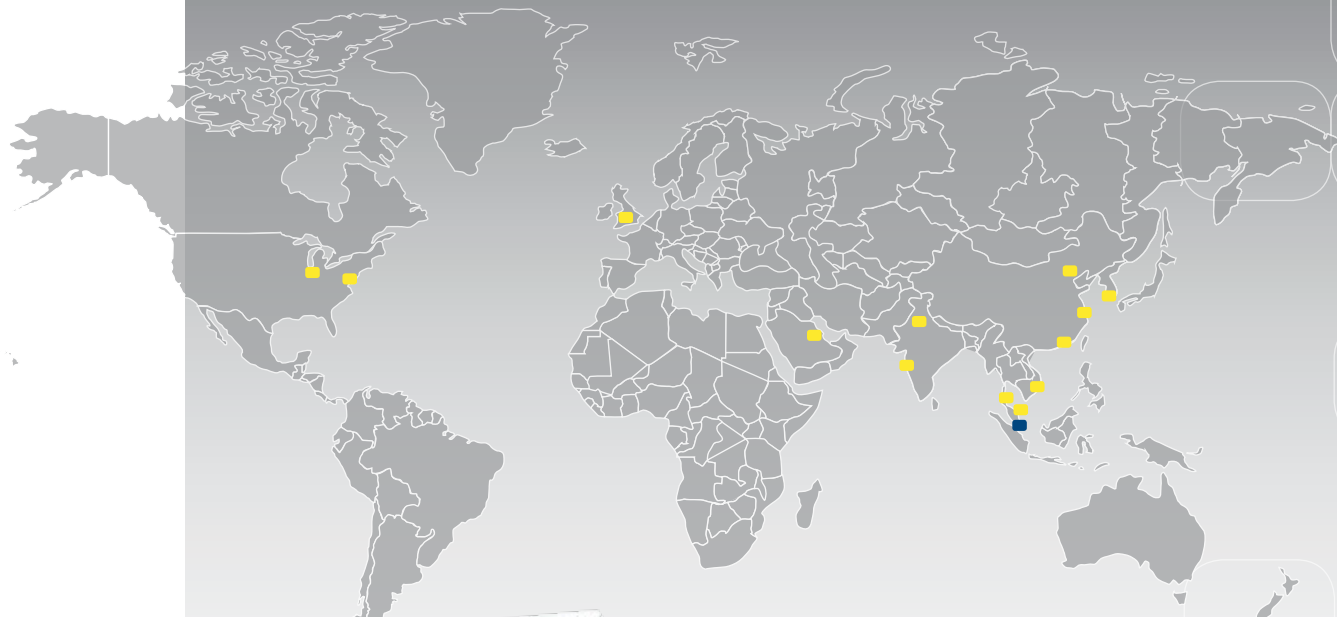

Biological Safety Products
 Cleanroom Products
 Containment / Pharma Products
 Ductless Fume Hoods / Carbon Filtration
 General Purpose Scientific Equipment
 Industrial Lab Equipment
 In-Vitro Fertilization Products
 PCR Products
 Pharmacy Products
 Lab Animal Research Products
 Lab Thermostatics Products
 Lab Ventilation / Chemical Fume Products / Lab Furniture
 Powder Handling Products

Since 1978, Esco has emerged as a leader in the development of controlled environment, laboratory and cleanroom equipment solutions. Products sold in more than 100 countries include biological safety cabinets, fume hoods, ductless fume hoods, laminar flow clean benches, animal containment workstations, cytotoxic cabinets, hospital pharmacy isolators, and PCR cabinets and instrumentation. With the most extensive product line in the industry, Esco has passed more tests, in more languages, for more certifications, throughout more countries than any biosafety cabinet manufacturer in the world. Esco remains dedicated to delivering innovative solutions for the clinical, life science, research and industrial laboratory community. www.escoglobal.com.

Airflow Alarms and Monitors • Biological Safety Cabinets • Exhaust Blowers
 Benchtop Laboratory Fume Hoods • High Performance Low Flow Fume Hoods

ESCO

WORLD CLASS. WORLDWIDE.

AUSTRALIAN DISTRIBUTORS:

Fisher Biotec Australia

Freecall: 1800 066 077

www.fisherbiotec.com

email: info@fisherbiotec.com