

NEW!

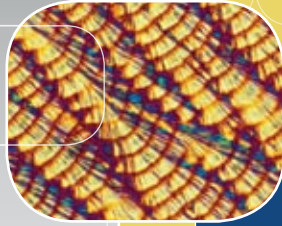

Esco Frontier Duo™ Laboratory Fume Hood,
Model EFD-4B...
(Shown with optional base cabinet)

Frontier•DUO®

Laboratory Fume Hoods

Introduction

The Esco Frontier Duo Fume Hood offers a solution representing design and engineering innovations that are at the forefront of fume hood technology, providing superior containment of noxious chemical fumes at a broad range of face velocities while addressing worker comfort through ergonomic design. Work zone baffles and aerodynamic airfoil are designed with computational fluid dynamics to enhance safety.

Superstructure

- Rugged dual-wall construction allows service fixture remote controls and electrical outlets to be mounted outside the work zone within easy reach.
- Fabricated of electrogalvanized steel (zinc coated to prevent rusting even if the powder coat is abraded, and phosphated for better adhesion of the powder coating).
- Epoxy-polyester hybrid Isocide™ antimicrobial powder coating provides long term chemical, abrasion and weathering resistance.
- State-of-the-art baffle system constructed of phenolic resin laminates delivers maximum containment by ensuring airflow uniformity throughout the main chamber.
- Corrosion-resistant epoxy powder coated electrogalvanized steel airfoil safely ventilates fumes generated towards the front of the hood for superior operator protection.
- Standard vertical rising fail safe counterbalanced sash constructed of safety glass maximizes operator safety. The safety mechanism causes sash to tilt and lock if a cable snaps.
- Dished work top provides spill retention and is constructed of phenolic resin, a highly corrosion-resistant material.
- 1 remote-control gas fixture and 1 remote-control water fixture (with high quality PP drip cup) are provided with every hood. Additional services should be ordered separately.

- 4 electrical outlets are provided with every hood (total rating 5A). Additional outlets should be ordered separately (specify amps required).

Aesthetics and Ergonomics Design

- Perfect Pitch Profile - The gentle pitch of the hood enhances visibility and enables users to work further into the hood without strain.
- The angled front is also an aesthetic feature that positions your laboratory for the 21st century.
- Complementary color scheme (neutral white with blue accents) blends the hood with any casework, metal or wood.
- Hood lighting is pre-wired. Lighting is electronically ballasted, energy efficient, instant start. Typical light intensity on work surface is >780 lux (>72 foot candles) in zero ambient conditions.
- Color temperature is tuned to provide a gentle, bright (but not harsh) and comfortable work environment for the user.

Serviceability

- Removable front panel enables easy access to lighting and other electrical components mounted above the hood work chamber.



Electrical panel is located at the front to allow easy servicing.

Safety Certified and Tested

All Esco fume hoods are manufactured for the most demanding laboratory applications.

- Independently tested and certified by Invent, UK to meet the requirement of the ANSI/ASHRAE 110-1995 Standard.
- Hoods are ASHRAE tested on the production line on a sampling basis (industry exclusive).
- Sash is clearly labeled with all operating instructions and illustrations.

Accessories and Options

Esco offers a variety of options and accessories to meet application requirements.

- Additional services and electrical outlets.
- Fully configurable optional Esco Sentinel Microprocessor control provides a continuous display of face velocity. The alarm system will alarm should the face velocity within the work zone fall to a low level that compromises operator safety.
- Optional motorized sash window for improved operator convenience.
- Base cabinetry is available for additional storage area in the laboratory.
- Optional distillation grids can be ordered separately for factory installation.
- Ceiling closure panels may be custom-made by Esco or supplied by our local Sales Representative.
- C-frame support stand with leveling feet (SFL-__ _0).

General Specifications, Frontier Duo Fume Hoods

Model	EFD-4 _ _	EFD-5 _	EFD-6 _	EFD-8 _ _					
Nominal size	1.2 meters (4')	1.5 meters (5')	1.8 meters (6')	2.4 meters (8')					
External Dimensions (W x D x H)	1200 x 795 x 1500 mm 47.2" x 31.3" x 59.0"	1500 x 795 x 1500 mm 59.0" x 31.3" x 59.0"	1800 x 795 x 1500 mm 70.9" x 31.3" x 59.0"	2400 x 795 x 1500 mm 94.5" x 31.3" x 59.0"					
Internal Work Area, Dimensions (W x D x H)	1000 x 590 x 1260 mm 39.4" x 23.2" x 49.6"	1300 x 590 x 1260 mm 51.2" x 23.2" x 49.6"	1600 x 590 x 1260 mm 63" x 23.2" x 49.6"	2200 x 590 x 1260 mm 86.6" x 23.2" x 49.6"					
Maximum Sash Opening	600 mm (23.6")								
Exhaust Volume/ Static Pressure Required Face Velocity of 0.5m/s (100 fpm) at Full Open Sash	1296 cmh @ 70 Pa 763 cfm @ 0.28" WG	1400 cmh @ 75 Pa 824 cfm @ 0.30" WG	1543 cmh @ 86 Pa 908 cfm @ 0.34" WG	2372 cmh @ 80 Pa 1396 cfm @ 0.32" WG					
Exhaust Outlet Diameter	305 mm (12")								
Number of Exhaust Collars	1	1	1	2					
Flourescent Light Intensity	800 Lux (74.3 foot candles)								
Construction	External Side Walls and Front Panel								
	Oven-baked epoxy powder-coated EG steel								
Internal Liner and Baffle System	Esco Resinate phenolic resin laminates								
	Esco Resinate phenolic resin laminates								
Power Consumption	25W (Fluorescent Lighting Only) / 60W (Fluorescent Lighting and Microprocessor Control System)								
Electrical*	220-240V, AC, 50Hz, 1Ø	EFD-4A1	EFD-4B1	EFD-5A1	EFD-5B1	EFD-6A1	EFD-6B1	EFD-8A1	EFD-8B1
	Cabinet Full Load Amps (FLA)	10 A	1 A	10 A	1 A	10 A	1 A	10 A	1 A
	Cabinet BTU**	205	341	341	341	341	341	410	341
	110-120V, AC, 60Hz, 1Ø	EFD-4A2	EFD-4B2	EFD-5A2	EFD-5B2	EFD-6A2	EFD-6B2	EFD-8A2	EFD-8B2
	Cabinet Full Load Amps (FLA)	10 A	1 A	10 A	1 A	10 A	1 A	10 A	1 A
	Cabinet BTU**	205	341	341	341	341	341	410	341
	220-240V, AC, 60Hz, 1Ø	EFD-4A3	EFD-4B3	EFD-5A3	EFD-5B3	EFD-6A3	EFD-6B3	EFD-8A3	EFD-8B3
	Cabinet Full Load Amps (FLA)	10 A	1 A	10 A	1 A	10 A	1 A	10 A	1 A
Cabinet BTU**	205	341	341	341	341	341	410	341	
Controller	Choose from the following controller configuration codes when ordering (e.g. EFD-4A3, for Rocker Switches) A: Rocker Switches B: Sentinel™ Microprocessor control								
Net Weight	157 kg (346 lbs)	181 kg (399 lbs)	205 kg (451 lbs)	283 kg (623 lbs)					
Shipping Weight	211.7 kg / 467 lbs	243 kg / 536 lbs	287.3 kg / 633 lbs	293.5 kg / 647 lbs					
Shipping Dimensions, Maximum (W x D x H)	1300 x 950 x 1940 mm 51.2" x 37.4" x 76.4"	1600 x 950 x 1940 mm 63.0" x 37.4" x 76.4"	1950 x 950 x 1940 mm 76.8" x 37.4" x 76.4"	2500 x 950 x 1940 mm 98.4" x 37.4" x 76.4"					

* The maximum rating of all the electrical outlets combined is 5 Amp. Please contact Esco if you need electrical outlets with higher capacity.

** Cabinet BTU = Cabinet nominal power x 3.41214

General Specifications, Base Cabinet for Frontier Duo Fume Hoods

Model	EBD-4A0	EBD-5A0	EBD-6A0	EBD-8A0
Nominal size	1.2 meters (4')	1.5 meters (5')	1.8 meters (6')	2.4 meters (8')
External Dimensions (W x D x H)	1200 x 770 x 860 mm 47.2" x 30.3" x 33.8"	1500 x 770 x 860 mm 59.0" x 30.3" x 33.8"	1800 x 770 x 860 mm 70.9" x 30.3" x 33.8"	1200 x 770 x 860 mm 94.5" x 30.3" x 33.8"
Net Weight	76 kg (168 lbs)	82 kg (181 lbs)	98 kg (216 lbs)	136 kg (300 lbs)
Shipping Weight	109 kg / 240 lbs	145kg / 319.7 lbs	206.7 kg / 456 lbs	235.6 kg / 519 lbs
Shipping Dimensions, Maximum (W x D x H)	1350 x 750 x 1100 mm 53.1" x 29.5" x 43.3"	1600 x 750 x 1100 mm 63.0" x 29.5" x 43.3"	1950 x 750 x 1100 mm 76.8" x 29.5" x 43.3"	2500 x 780 x 1100 mm 98.4" x 30.7" x 43.3"

Frontier•DUO

Fume Hoods • Laboratory Fume Hoods

Model EFD (B-Series) Frontier Duo Fume Hood Technical Specifications

Top View (for EFD-4, EFD-5, EFD-6)

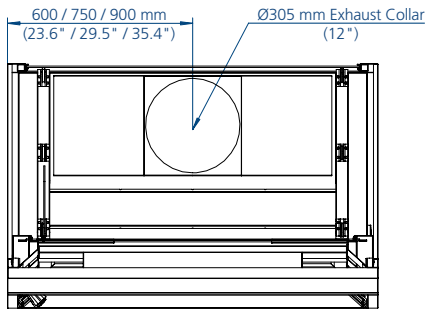

Top View (for EFD-8)

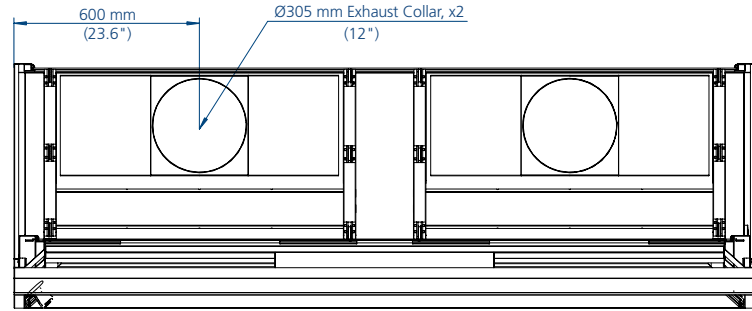

Front View

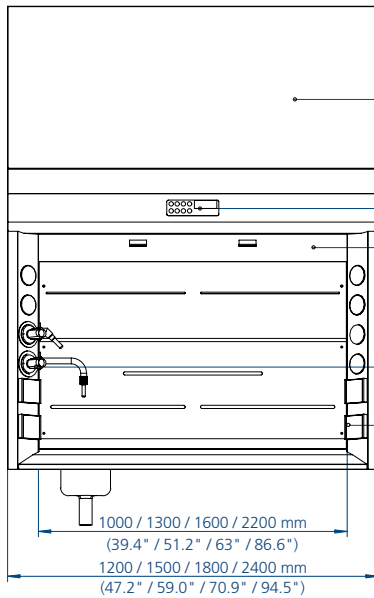

Side View

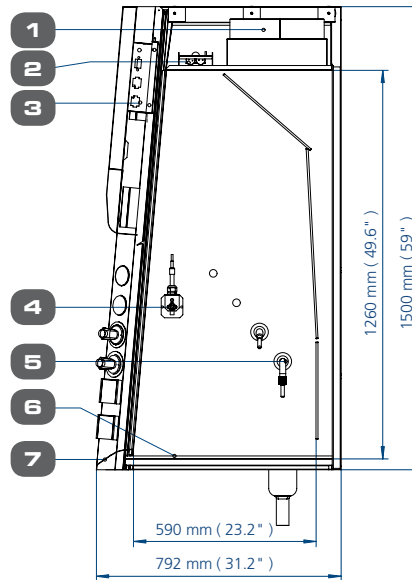

1. Exhaust collar
2. Fluorescent lamp
3. Electrical panel
4. Airflow sensor (optional)

5. Service fixture outlet
6. Dished work top
7. Ergonomic airfoil
8. Electrical outlet

9. Service fixture remote control
10. Sash window
11. Sentinel microprocessor control system (optional)
12. Removable front panel

Model EBD Base Cabinet for Frontier Duo Fume Hood Technical Specifications

Top View

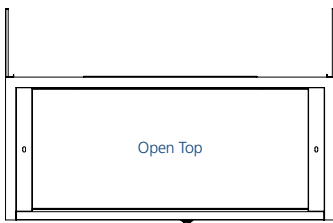

Rear View

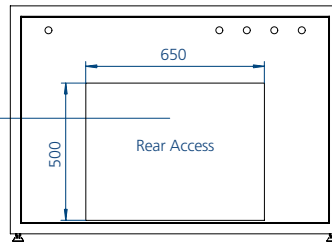

Front View

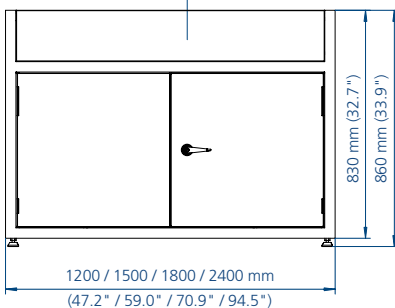

Side View

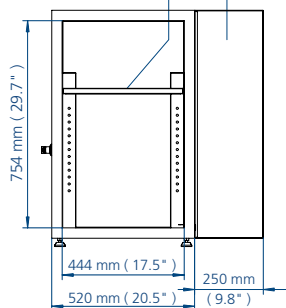

1. Removable Front Panel
2. Adjustable Shelf
3. Side Filler Panel
4. Rear Access for plumbing

Fume Hood Installation Requirements

- Proper location (refer to Esco recommendations)
- Exhaust system capable of delivering airflow and pressure drop requirements
 - Exhaust ductwork and connection accessories
 - Exhaust blower (or building exhaust system)
 - Contactor (if applicable)
 - Means of adjusting exhaust flow (damper or frequency inverter)
- Sufficient laboratory supply air
- Base cabinet or other means of support
- Plumbing and electrical hook-up
- Unless otherwise specified, items and services specified above are not provided by Esco



- Biological Safety Products
- Cleanroom Products
- Containment / Pharma Products
- Ductless Fume Hoods / Carbon Filtration
- General Purpose Scientific Equipment
- Industrial Lab Equipment
- In-Vitro Fertilization Products
- PCR Products
- Pharmacy Products
- Lab Animal Research Products
- Lab Thermostatic Products
- Lab Ventilation / Chemical Fume Products / Lab Furniture
- Powder Handling Products

Since 1978, Esco has emerged as a leader in the development of controlled environment, laboratory and cleanroom equipment solutions. Products sold in more than 100 countries include biological safety cabinets, cleanroom products, compounding pharmacy equipment, containment / pharma products, ductless fume hoods, in vitro fertilization workstations, lab animal research products, laboratory fume hoods, laboratory ovens and incubators, laminar flow clean benches and PCR products and instrumentation. With the most extensive product line in the industry, Esco has passed more tests, in more languages, for more certifications, throughout more countries than any biosafety cabinet manufacturer in the world. Esco remains dedicated to delivering innovative solutions for the clinical, life science, research and industrial laboratory community. www.escoglobal.com.

Airflow Alarms and Monitors • Biological Safety Cabinets • Exhaust Blowers
 Benchtop Laboratory Fume Hoods • High Performance Low Flow Fume Hoods

ESCO

WORLD CLASS. WORLDWIDE.

AUSTRALIAN DISTRIBUTORS:

Fisher Biotec Australia
 Freecall: 1800 066 077
www.fisherbiotec.com
 email: info@fisherbiotec.com



9010035_Eumbood_EFD_Schiberg_A4_v01_06/11
 Esco reserves the right to alter its products and specifications without notice. All trademarks and logos in this material are the property of Esco and the respective companies.